

PRODUCT DATA

SingleUp 3015
2000 kg

Garage without door (basement garage)

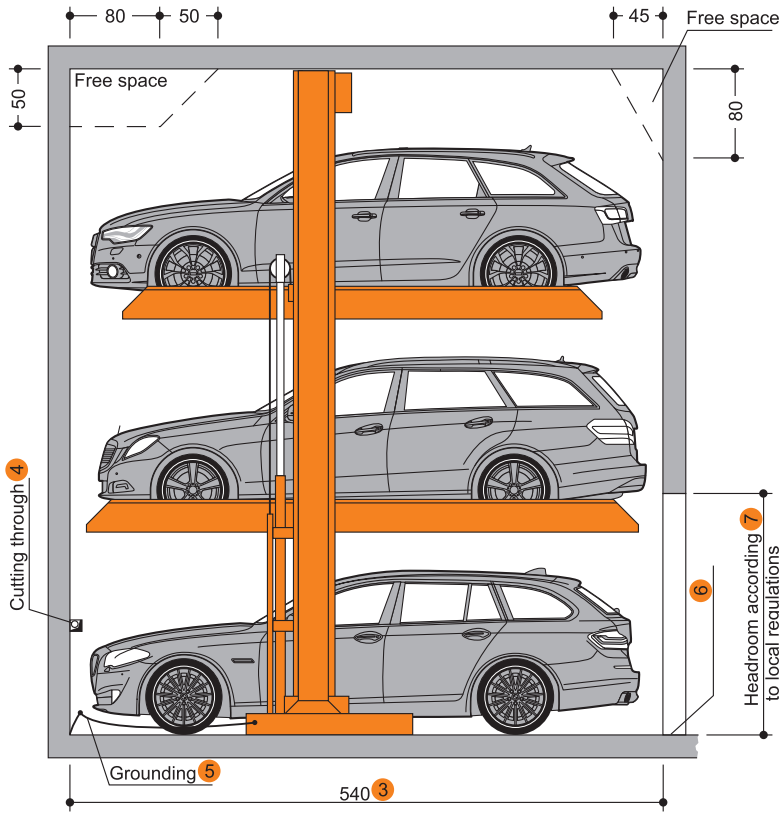

Dimensions

All space requirements are minimum finished dimensions.

Tolerances for space requirements $+3$ 0 . **2**
Dimensions in cm.

EB (single platform) = 2 vehicles

Suitable for

Standard passenger cars

For PW 2.3 m according to clearance and maximal surface load

Width	190 cm
Weight	max. 2000 kg
Wheel load	max. 500 kg

Clearance profile

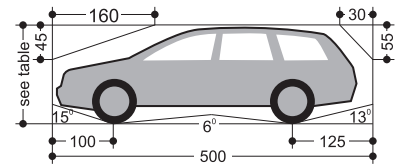

3015-560

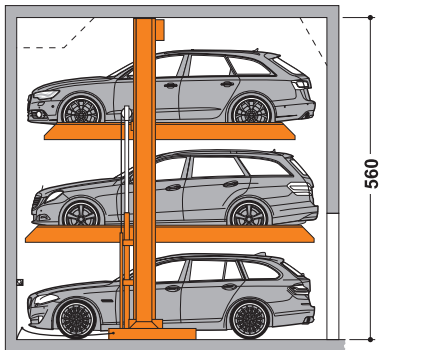

Height	Car height upper	Car height middle	Car height lower
560	160	160	180

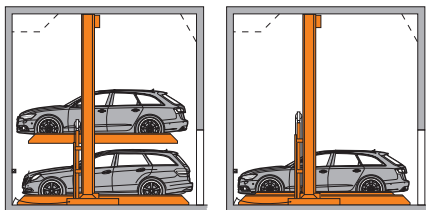

3015-615 **1**

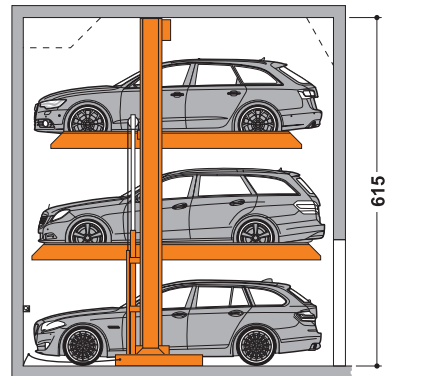

Height	Car height upper	Car height middle	Car height lower
615	180	180	180

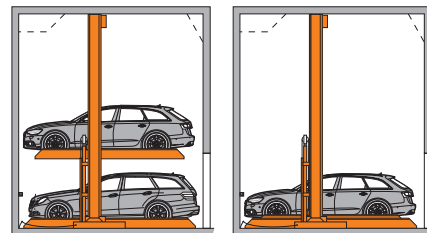

- Standard type
- To follow the minimum finished dimensions, make sure to consider the tolerances, during construction.
- If the total length is greater, the max. vehicle length for the lower parking space increases accordingly.
- For dividing walls : cutting through 10 x 10 cm.
- Potential equalization from foundation grounding connection to system (provided by the customer).
- 10 cm wide yellow-black markings must be applied by the customer to the edge of the platform in the access area to mark the danger zone in front of the supporting surface of the upper platform edge (see "Load Plan" Page 2).
- Must be at least as high as the greatest car height + 5 cm.

Page 1
- Section
- Dimensions
- Car data

Page 2
- Width dim.
- Function
- Approach
- Load plan

Page 3
- Electrical Installation
- Technical data
- To be performed by the customer

Page 4
- Description

Width dimensions for garage without door (basement garage)

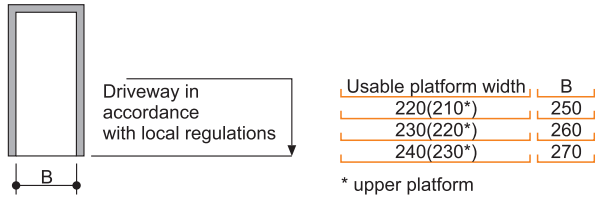

Function

System lifted

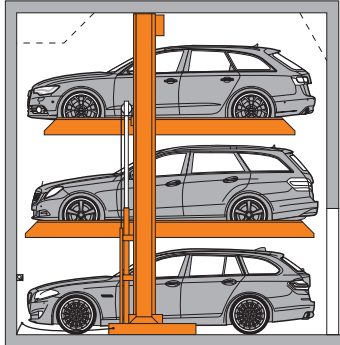

Before lowering the platforms, the vehicle parked on the lower parking space must be driven off.

System in middle position

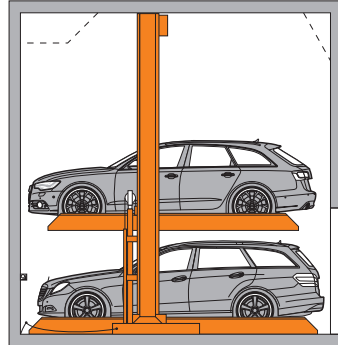

Before lowering the upper platform, the vehicle parked on the lower platform must also be driven off.

System lowered

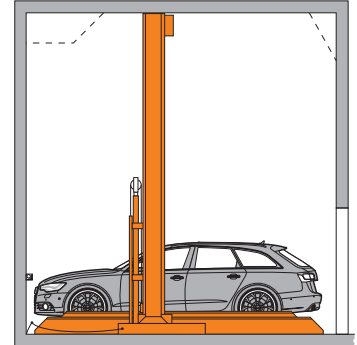

Approach

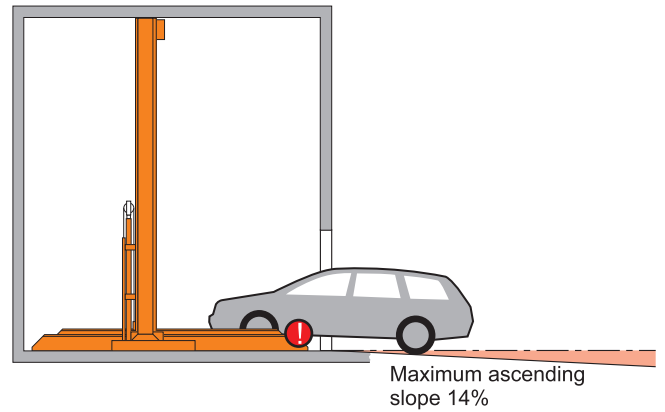
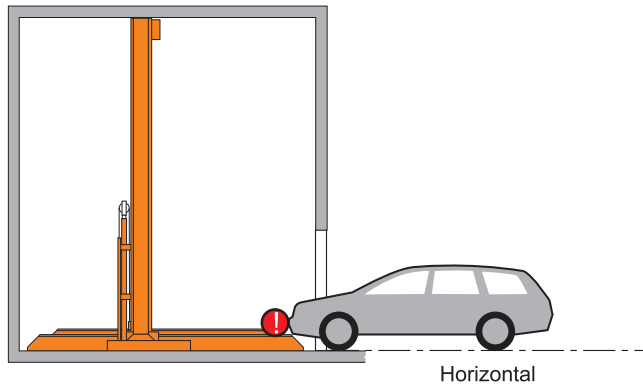

! The illustrated maximum approach angles must not be exceeded. Incorrect approach angles will cause serious maneuvering and positioning problems on the parking system for which the local agency of KLAUS Multiparking accepts no responsibility.

Load plan

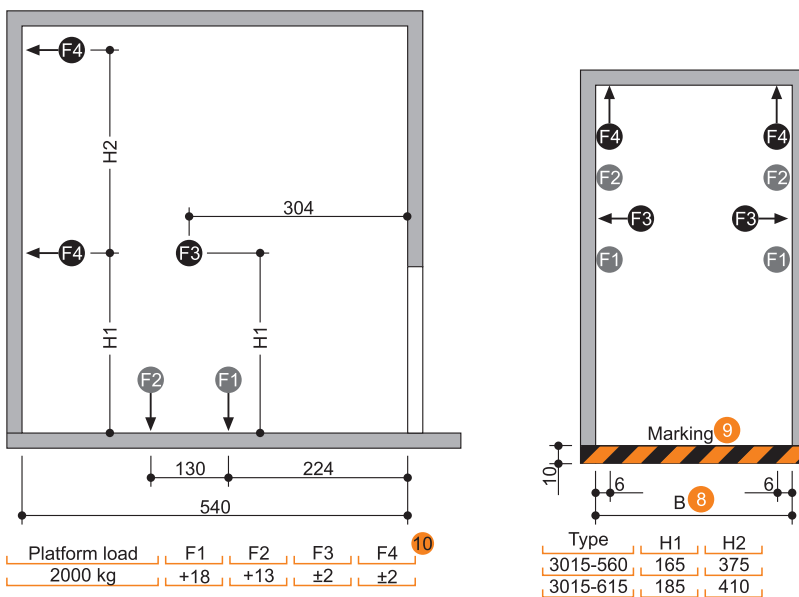

8 Dimension B see page 2
9 Marking (colors used in this illustration are representatives)
10 All forces in kN (static loads)

! Units are doweled to the floor. Drilling depth: approx. 15 cm.
Floor and walls are to be made of concrete (quality minimum C20/25).
The dimensions for the points of support are rounded values. If the exact position is required, please contact KLAUS Multiparking.

Page 1
-Section
-Dimensions
-Car data

Page 2
-Width dim.
-Function
-Approach
-Load plan

Page 3
-Electrical Installation
-Technical data
-To be performed by the customer

Page 4
-Description

Electrical installation

Installation diagram

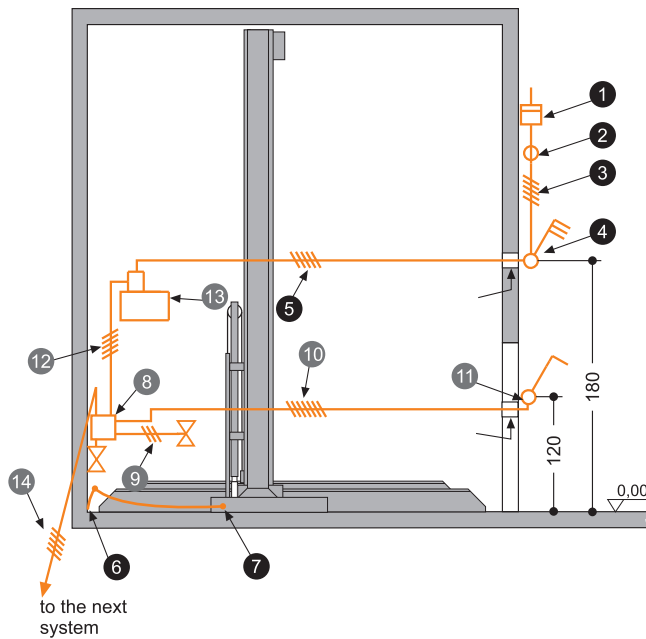

Electrical data (to be performed by the customer)

No.	Quantity	Description	Position	Frequency
1	1	Electricity meter	In the supply line	
2	1	Main power point: 4 pole RCBO (or MCB + ELCB), 16 Amp IDN (sensitivity/leakage current) 100 mA	In the supply line	1 per unit
3	1	Supply line 5 x 4.0mm ² , copper (3PH + N + PE) with marked wire and protective conductor	To main switch	1 per unit
4	1	N.A.		
5	1	Supply line 5 x 4.0mm ² (3PH + N + PE) with marked wire and protective conductor	From main switch to unit	1 per unit
6	every 10 m	Foundation earth connector	Corner pit floor	
7	1	Equipotential bonding from foundation earth connector to the system		1 per system

Electrical data (included in delivery of KLAUS Multiparking)

No.	Description
8	Terminal box
9	Control line 3 x 0.75 mm ² (PH + N + PE)
10	Control line 5 x 0.75 mm ² with marked wire and protective conductor
11	Operating device
12	Control line 5 x 0.75 mm ² with marked wire and protective conductor
13	Hydraulic unit 3.0 kW, three-phase current, 415 V / 50 Hz
14	Control line 5 x 0.75 mm ² with marked wire and protective conductor

Technical data

Field of application

Generally parking system is suitable for same car length for which the wheel stop is adjusted at the time of installation. In case different car is to be parked, wheel stop adjustment/confirmation from KLAUS Multiparking shall be required.

Care

To avoid damages resulting from corrosion, make sure to follow our cleaning and care instructions and to provide good ventilation of your garage.

Railings

If there are traffic routes next to or behind the installations, railings must be installed by the customer. Railings must also be in place during construction.

Environmental conditions

Environmental conditions for the area of multiparking systems: Temperature range 5°C to +40°C. Maximum outside temperature of +45°C.

If the local circumstances differ from the above, please contact KLAUS Multiparking.

To be performed by the customer

Safety fences

Any constraints that may be necessary in order to provide protection for the pathways directly in front, next to or behind the unit. This is also valid during construction.

Numbering of parking spaces

Consecutive numbering of parking spaces.

Building services

Any required lighting, ventilation, fire extinguishing and fire alarm systems as well as clarification and compliance with the relevant regulatory requirements.

Marking

A warning that identifies this danger area must be placed in the entrance area. This must be done for systems without a pit 10 cm from the edge of the platform.

Wall cuttings

Any necessary wall cuttings according to page 1.

Electrical supply to the main power point

A 3 phase, 415 V (±10%) 50 Hz (±2%) 4 wire (3 PH + N + PE) electrical supply to the main power point and the control wire line (5 x 2.5 mm², copper 3 PH + N + PE) with marked wire and protective conductor must be provided by customer during installation.

The functionality can be monitored on site by our filters together with the electrician. If this cannot be done during installation for some reason for which the customer is responsible, the customer must commission an electrician at their own expense and risk.

Safety of machinery, electrical equipment), grounding of steel structure is necessary, provided by the customer (distance between grounding max. 10 m).

Description Single platform (EB)

General description

KLAUS Multiparking system providing dependent parking spaces for 3 cars one on top of the other each. The lower vehicle parks directly on the floor plate. The vehicle parked on the bottom must be driven out before lowering the platform.

Dimensions are in accordance with the underlying dimensions of height and width

The parking bays are accessed horizontally (installation deviation $\pm 1\%$).

The user is responsible for positioning the vehicle.

Operation via operating device with hold-to-run-device using master keys.

The operating elements are usually mounted either in front of the column or on the outside of the door frame

Operating instructions are attached to each operator's stand.

For safety reasons, it is recommended to install safety doors at the entrance.

For garages with doors at the front of the parking system the special dimensional requirements have to be taken into account.

Multiparking system consists of

- 2 steel pillars with base plates (mounted on the floor)
- 2 sliding platforms (mounted to the steel pillars with sliding bearings)
- 2 platform
- 1 mechanic synchronization control system (to ensure synchronous operation of the hydraulic cylinders while lowering and lifting the platform)
- 2 hydraulic cylinder
- 1 automatic mechanical locking system (prevents accidental lowering the platforms)
- Dowels, screws, connecting elements, bolts, etc.
- The platforms and parking spaces are end-to-end accessible for parking.

Platforms consist of

- Platform base sections
- Canted access plates
- Side members
- Cross members
- Screws, nuts, washers, distance tubes, etc.

Hydraulic system consists of

- Hydraulic cylinder
- Solenoid valve
- Hydraulic pipes
- Screwed joints
- High-pressure hoses
- Installation material

Electric system consists of

- Operating device (Emergency Stop, lock, 1 master key per parking space)
- Terminal box at wall valve

Hydraulic unit system consists of

- Hydraulic power unit (low-noise, installed onto a console with metal mounting)
- Hydraulic oil reservoir
- Oil filling
- Internal geared wheel pump
- Pump holder
- 3-phase-AC-motor
- Contactor (with thermal over current relay and control fuse)
- Pressure gauge
- Pressure relief valve
- Hydraulic hoses (which reduce noise transmission onto the hydraulic pipe)

We reserve the right to change these specifications without prior notice.

KLAUS Multiparking reserves the right in the course of the technical progress to use newer or other technologies, system, processes, procedures or standards in the fulfillment of their obligations other than those originally offered.

Page 1
- Section
- Dimensions
- Car data

Page 2
- Width dim.
- Function
- Approach
- Load plan

Page 3
- Electrical Installation
- Technical data
- To be performed by the customer

Page 4
- Description